

OPERATING INSTRUCTIONS

OLYMPIA SM9



We are very proud indeed to count you as another OLYMPIA user. Your OLYMPIA will give you many years of pleasure. This instruction booklet will tell you about the advantages and operation of OLYMPIA SM 9. Please read the booklet carefully before you start to use the machine — you will find many useful hints which will help you to keep your OLYMPIA in first-class condition. And now — our very best wishes to you and your OLYMPIA.

Operating Instructions

OLYMPIA WERKE AG. WILHELMSHAVEN

THIS IS A LOW-RESOLUTION BLACK-AND-WHITE FREE VERSION.

Preparing for use

Remove the typewriter from its case and take off the rubber bands from the carriage release lever (19) and the carriage lock lever (7). Lift up the line spacing lever (9) and remove the synthetic transit lock from the left side of the carriage rails (Fig. 1). Then slide the carriage to the right and carry out the same procedure for the R. H. synthetic transit lock. Grip the front cover on both sides, lift up, and remove the piece of cardboard which protects the typebars. Remove the pieces of synthetic fitted beneath the L. H. and R. H. ribbon spools (Fig. 2). Once the shift lock key (13) has been operated, the machine is ready for use.

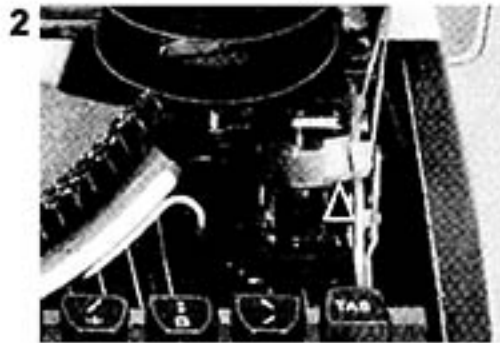
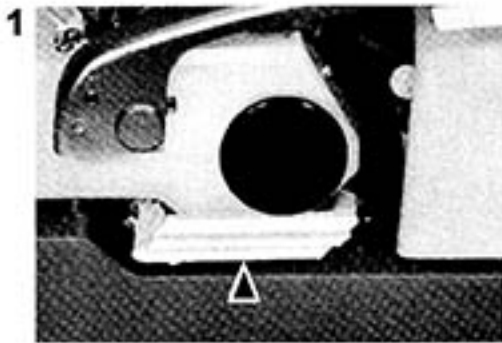

Lowering the noise level

Raise the line spacing lever to allow the carriage to be slid to the right and to select the next typing line.

Line spacing lever (9)

In order to reduce the noise level, the machine should, if possible, be placed on a soft felt pad.

THIS IS A LOW-RESOLUTION BLACK-AND-WHITE FREE VERSION.

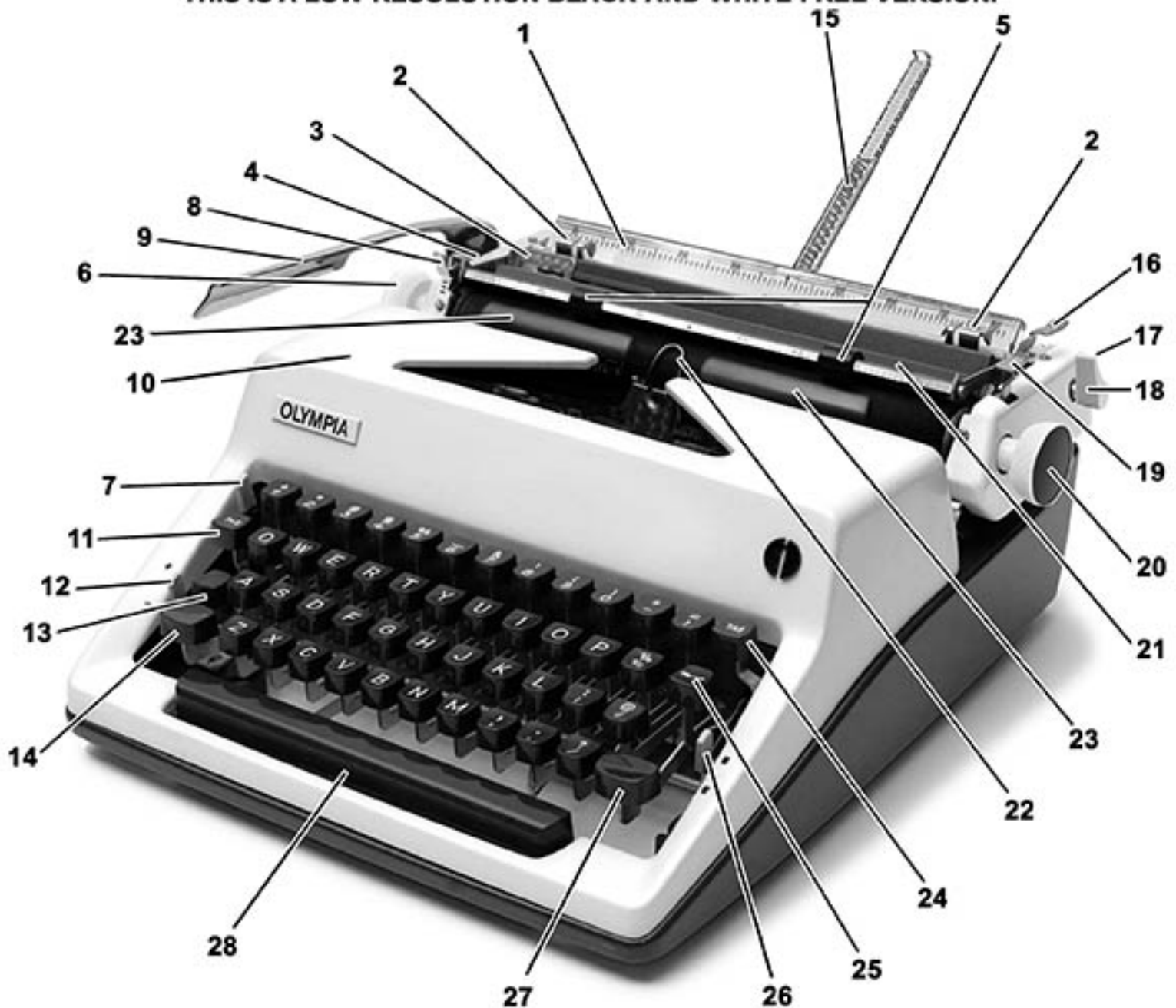

- | | | |
|---|---|--|
| 1 Margin stop scale | 10 Impression regulator (beneath front cover) | 19 Right hand carriage release |
| 2 Margin stops | 11 Margin release | 20 Right hand platen knob |
| 3 Paper guide | 12 Tab set/clear selector | 21 Paper erasure table |
| 4 Left hand carriage release (not shown) | 13 Shift lock key | 22 Card holder |
| 5 Paper bail with rollers | 14 Left hand shift key | 23 Aligning scale with drawing notches |
| 6 Left hand platen knob | 15 Paper support | 24 Tab key |
| 7 Carriage lock lever | 16 Paper release | 25 Backspace key |
| 8 Line spacing selector with platen release | 17 Paper support release button (not shown) | 26 Ribbon selector |
| 9 Line spacing lever | 18 Total tab clearance lever | 27 Right hand shift key |
| | | 28 Correcting spacebar |

ORDER PREMIUM HIGH-RESOLUTION COLOR OPERATING INSTRUCTIONS:

CLASSICVINTAGETYPEWRITERS.COM

Ribbon selection

In the case of the bichrome ribbons, the selector switch (26) should be set to the top position for black or to the bottom position for red. The white (center) position is for stencils. In the case of single-color ribbons, these should be reversed once the top half is worn out to obtain the maximum possible use of the lower section of the ribbon. Ribbon advance and return are automatic.

Inserting the paper

Slide the carriage to its center position and raise the paper support (15) by applying pressure to the release button (17). Position the paper against the adjustable paper guide (3), insert between the platen and erasure table and rotate either of the platen knobs (6/20) to bring the paper to the desired level. To align the paper horizontally and to insert the desired number of copies, move forward the paper release lever (16).

Selecting the margins

The Left hand and Right hand margins can be selected by depressing the margin stops (2) and sliding them to the desired positions.

Line spacing selector (8)

The desired line spacing can be selected by moving the selector to the appropriate setting.

Margin release lever (11)

The Left hand and Right hand margins can be overridden by the operation of this lever.

Margin alignment

If required, texts can be typed to give the appearance of a printed sheet due to the incorporation of a device which allows for the compensation of the right hand margin. The selected text should first be typed in draft form to ascertain how many letters per line must be compensated. An average line of this draft should then be selected as a guide, and a vertical line drawn at the end of this line from top to bottom of the complete draft.

To shorten a line, slide the carriage back to the last letter of the preceding word, depress the spacebar, type the first letter of the next word, release the spacebar, depress the space-bar, and type the second letter of the word etc. Once the last letter of the word has been typed, operate the spacebar once only.

To lengthen a line, slide the carriage back to the last letter of the last word, operate the spacebar once only, depress the spacebar, type the first letter of the next word and release the spacebar. Carry on in this manner until the complete word has been typed, and then operate the spacebar twice consecutively.

Olympia machines provide an
even right-hand margin - you
use the half-spacing feature
(without margin alignment)

Olympia machines provide an
even right-hand margin - you
use the half-spacing feature
(with margin alignment)

THIS IS A LOW-RESOLUTION BLACK-AND-WHITE FREE VERSION.

The exchange of the ribbon

Access to the ribbon mechanism can be obtained by applying pressure to both sides of the housing on either side of the spacebar and lifting the housing until it contacts its stops. Wind on the used ribbon on one of the spools (d), swing back the ribbon brake (a) remove the empty spool and disengage the hook of the used ribbon from the core of the spool (e). Remove the ribbon from the ribbon vibrator and wind the remainder of the ribbon on the full spool.

Fit the hook of the new ribbon to the core of the empty spool and fit the spool to its mounting, ensuring that the pin (c) engages in one of the guide holes (f). Fit the ribbon behind both reversing arms (b) and operate the shift lock key (13). Using both hands position the ribbon behind the ribbon vibrator (h) and into guides (g) as shown in the illustration. When using bichrome ribbons, the red section of the ribbon should be positioned at the bottom.

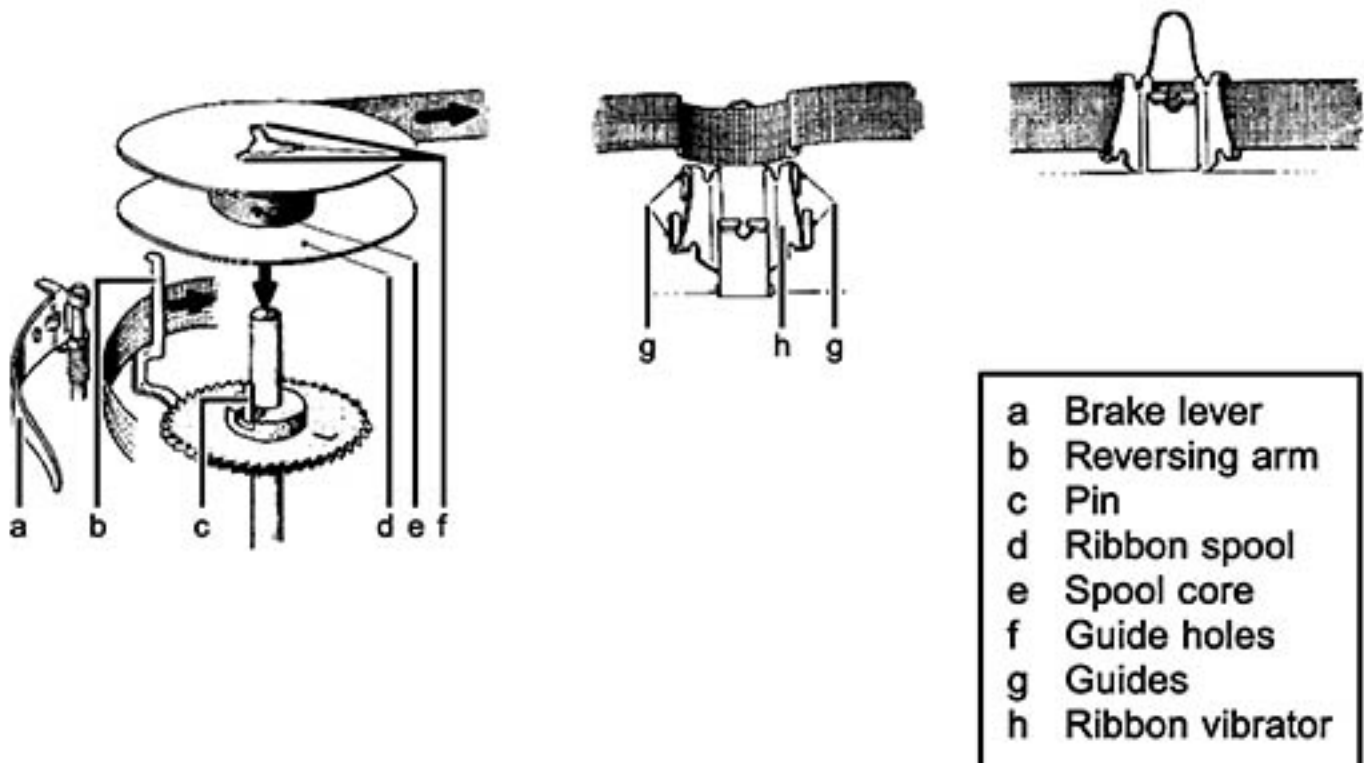

**ORDER PREMIUM HIGH-RESOLUTION COLOR OPERATING INSTRUCTIONS:
CLASSICVINTAGETYPEWRITERS.COM**

THIS IS A LOW-RESOLUTION BLACK-AND-WHITE FREE VERSION.



Olympia International