

THIS IS A LOW-RESOLUTION BLACK-AND-WHITE FREE VERSION.

KNOWLEDGE MEANS IMPROVED PERFORMANCE!



The **SM 3**

## OPERATING INSTRUCTIONS

will provide useful information to both old and new users, for in every model of the OLYMPIA progressive innovations are incorporated. The use of an OLYMPIA is the easiest thing imaginable, but it is even easier if you know your machine properly. It is in your own interest to read carefully the following instructions before operating your OLYMPIA.

*Olympia*

ORDER PREMIUM HIGH-RESOLUTION COLOR OPERATING INSTRUCTIONS:  
[CLASSICVINTAGETYPEWRITERS.COM](http://CLASSICVINTAGETYPEWRITERS.COM)

STEP BY STEP ...

---



*First of all*

Lay back the cover of the case and remove by sliding it out of the hinges. Remove all cardboard packing. Take the rubber band off the right hand platen knob (15).



*Taking out and making ready*

Press down the catch on the baseboard, lift the machine and draw it out from the rear baseboard fastening.

Remove the wire springs from the left and right of the carriage. To do this turn the machine on its back and press out the wires from under the sides, lifting them up in the direction of the carriage and shaking free.



Press down the shift key (23) thus raising the carriage, and remove the pieces of cork placed left and right under the carriage.



Lift up the front cover (19) and remove the cardboard which protects the typebars.

*Reducing noise*

The machine, which in itself makes little noise should be placed on a soft pad of felt or similar material. Only when in a hurry — perhaps while travelling — should the machine be left standing on the baseboard.

## THIS, TOO, IS NECESSARY

### Changing the ribbon

Lift up the front cover (19) of the machine, exposing the ribbon mechanism. Wind the worn ribbon on to one of the two spools (h). Pull out the spool catch (g) and removing the empty spool, free the end of the ribbon from the hook, and draw out of the ribbon guide (b). The spool carrying the old ribbon is now replaced by the new spool and ribbon. Put the free end of the ribbon on the projecting hook on the empty spool, and press the hook into the spindle.

Now replace the empty spool back on the machine taking care that both spools are firmly held by the conveyor pin (e). Thread the ribbon through the ribbon reverse levers (c) on both sides. Now press down the

shift lock, and take hold of the ribbon with both hands. Put the ribbon behind guide (b) and insert it into the left and right slits of the guide (a) so that its full width lies in the slits. When correctly fitted the position of the ribbon will correspond to that shown in the diagram

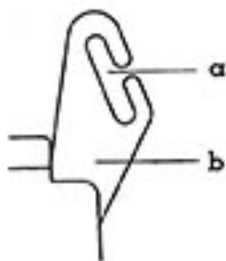

a) Ribbon holder  
b) Ribbon guide  
c) Ribbon reverse lever  
d) Guide hole

e) Conveyor pin  
f) Spool shaft  
g) Spool catch  
h) Ribbon spool

### Margin alignment

In order to preserve the good appearance of documents and circulars, it is sometimes required that the right hand margin should be as straight as the left. A rough draft of such work should first be typed so as to calculate the number of letters that require levelling on each line. The shortest line of the draft is taken as the standard and a vertical line is drawn at the end of this as shown in the example.

The letters on the other lines which are outside this limit must be inserted within it by means of the correcting space bar when the fair copy is typed.

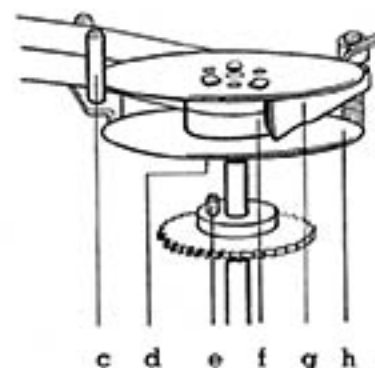
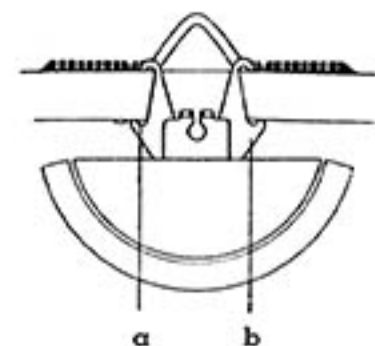

ORDER PREMIUM HIGH-RESOLUTION COLOR OPERATING INSTRUCTIONS:

CLASSICVINTAGETYPEWRITERS.COM

IS ALL THIS KNOWN ALREADY?

---



### *Ribbon Control*

With a two-colour ribbon set the ribbon switch (26) in the upper position for black, or the lower for red. The centre position (white) is for use when cutting duplicating stencils. When the upper half of single colour ribbon is worn-out invert for use of the lower part. Ribbon advance and return are automatic.

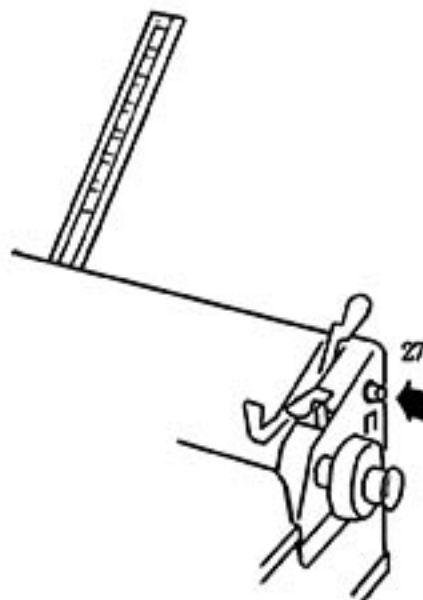

### *Inserting the paper*

Raise the paper support by pressing the release button (27). Lay the paper on the lateral paper guide (3) insert the paper between the paper table (8) and the platen and adjust it to the required height by turning the platen knobs (15). To adjust the paper or to insert several sheets pull the paper feed release lever (13) forward. The paper support is returned after use by pressing firmly to the right.

### *Margin control*

The beginning and end of the lines may be set to the required positions by adjusting the two margin stops (4). The margin stops are squeezed while being moved.

### *Line spacing*

The line space lever (2) may be set to give single, one-and-half, and double line spacing. Slight pressure on the line space lever (18) pushes the carriage along to the right and brings the paper into position for the next line.



### *Raising the carriage*

To type capital letters, punctuation marks etc. press down one of the two shift keys (23). Pressure on the shift lock (22) locks the carriage in the raised position. To lower the carriage again, press the left hand shift key.

### *Spacing*

On depressing and releasing the space bar (24) the carriage moves one space to the left.

THIS IS A LOW-RESOLUTION BLACK-AND-WHITE FREE VERSION.

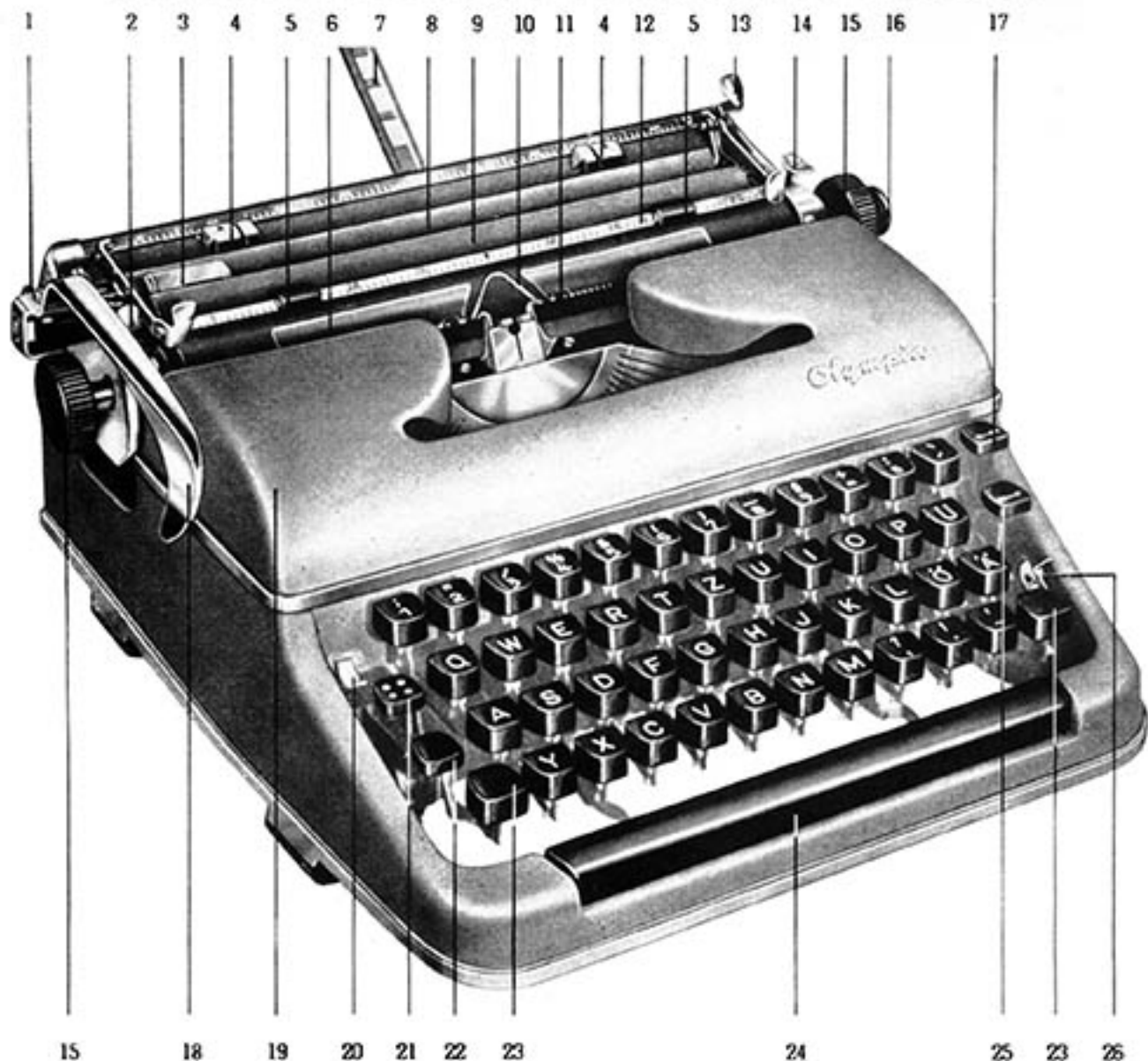

- 1 Platen release lever
- 2 Line space indicator
- 3 Paper guide
- 4 Margin stops
- 5 Paper scale roll
- 6 Alignment guide with perspex shield
- 7 Paper support
- 8 Paper table

- 9 Paper conductor
- 10 Postcard holder
- 11 Line drawing notches
- 12 Paper holder
- 13 Paper feed release
- 14 Carriage release
- 15 Platen knob
- 16 Line space plunger
- 17 Tabulator key

- 18 Line space lever
- 19 Front cover
- 20 Lock for carriage and keys
- 21 Margin release
- 22 Shift lock
- 23 Shift key
- 24 Space bar
- 25 Back space key
- 26 Ribbon and stencil switch

### *Margin release*

The ringing of the bell indicates that there are eight more spaces available before the end of the line; on reaching the end of the line the carriage will stop. Pressure on the margin release (21) however, releases the mechanism. Similarly pressure on the margin release enables typing to commence to the left of the limits set by the left hand margin stop.



ORDER PREMIUM HIGH-RESOLUTION COLOR OPERATING INSTRUCTIONS:

[CLASSICVINTAGETYPEWRITERS.COM](http://CLASSICVINTAGETYPEWRITERS.COM)

### ***Back Space Key***

Depressing the back space key (25) moves the carriage back one space i. e. the width of one letter.

### ***Carriage release***

Grip the right hand platen knob (15) with your right hand, and depress the carriage release lever (14) with the thumb. This allows the carriage to be moved freely in both directions.

### ***Platen Release***

By pressing the platen release (1) downwards the platen may be revolved freely. This is essential for work on ruled paper, or filling in forms as it enables an accurate return to the original line position when the release is elevated.

### ***Line Space Plunger***

By pressing the line space plunger (16) inwards, the platen will be freed; this enables a new line position to be found. The white vertical lines on the Alignment Guide (6) should be regarded as being the vertical centre of any letter. Use of these controls ensures accurate re-positioning of work.

### ***Touch control***

By moving the lever of the touch control (28) in the direction of the arrow the tension of the keys may be adjusted to suit the individual touch. The minimum pressure is required when the lever is forward to the full extent.

### ***Drawing lines***

Insert the point of a pencil in the notch in the alignment guide (11). By moving the carriage sideways, or by turning the platen knob, horizontal or vertical lines may be drawn.

### ***Erasing and Correcting***

Turn the platen until the part of the paper on which the mistake has been made lies on the paper conductor (9) and move the carriage to the side so that no eraser dust falls into the machine. Use a typewriter rubber and eraser shield for the top copy, and a soft rubber for carbon copies. Do not type omitted letters in between the others, but use the "correcting space bar". Rub out the wrongly typed word, and move the carriage back to the last letter of the preceding word. Tap the space bar once then depress the space bar and hold it in the down position; type the first letter and release the space bar; repeat this action throughout the wrongly typed word.

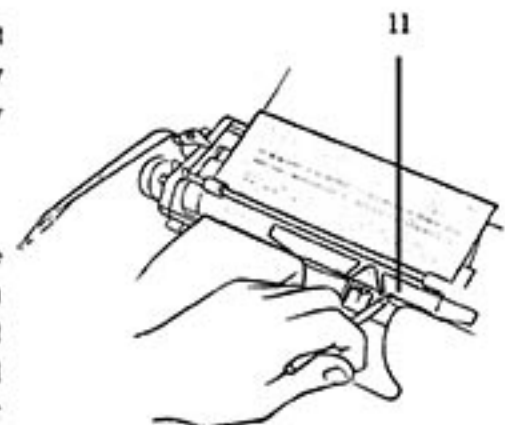
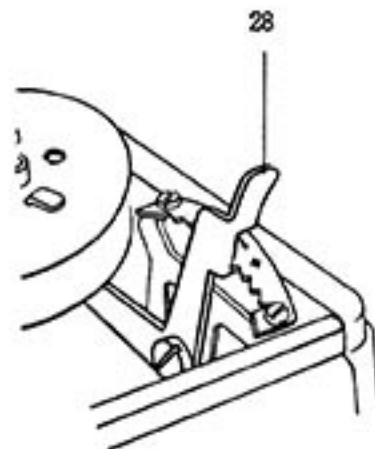

**THIS IS A LOW-RESOLUTION BLACK-AND-WHITE FREE VERSION.**

The best typewriter

(right)

The bst typewriter

(wrong)

The best typewriter

(corrected)

### ***Protection against damage***

When carrying the machine, or to prevent unauthorized or rough handling, lock the carriage and the keys by lifting up the locking lever (20) and sliding the carriage to its central position. To release the carriage and the keys push lever down.

The machine should be replaced in the case before transporting it any distance. Set the machine on the prongs at the rear of the baseboard and push into the clips, then press into the fastener at the front. Insert the case cover into the rear hinges of the baseboard, close and lock.

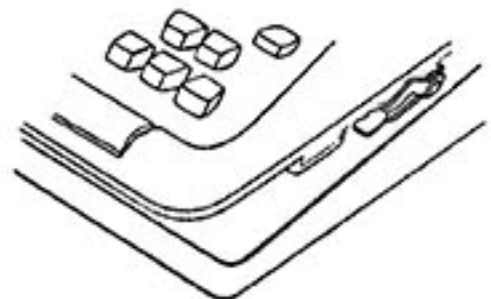

### ***Tabulation***

The use of the tabulator stops and key simplifies all work that requires tabulation. The tabulator stops (29) must first be set to the required positions and this is done by setting them to the same numbers on the scale at the back of machine (30) as is indicated at the required positions on the paper scale (12). The tabulator stops are easily moved by light pressure with the fingers, but care must be taken that the red mark on the tabulator stop is in exact alignment with the mark on the scale. Stops that are not required must be moved to left or right of the extreme margins.

Eight separate columns of typing may be produced by the use of all the tabulator stops in conjunction with the right hand margin stop and margin release key.

Pressure on the tabulator key (17) causes the carriage to glide automatically to the next tabulator stop. The key is released when the stop is reached.

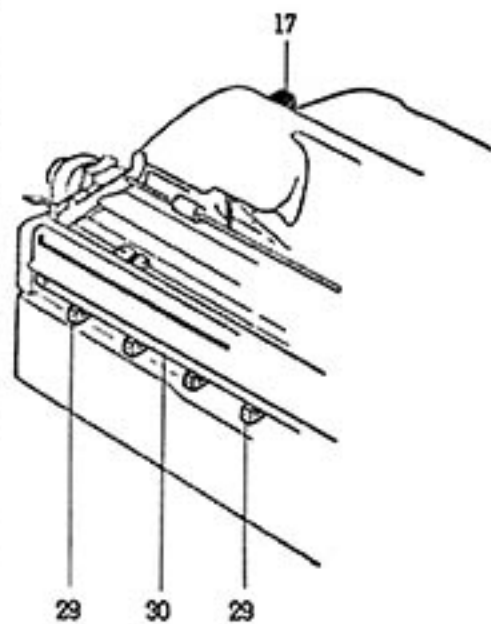

**ORDER PREMIUM HIGH-RESOLUTION COLOR OPERATING INSTRUCTIONS:**

**CLASSICVINTAGETYPEWRITERS.COM**

## THIS IS A LOW-RESOLUTION BLACK-AND-WHITE FREE VERSION.

Instead of making the shortest line the standard, another line of average length may be selected and the vertical line drawn from there. In this case any letters outside the line must be compressed within it, whilst lines which are shorter must be extended.

the advantage of which  
can be easily assessed  
as it dispenses with the

without margin alignment

the advantage of which  
can be easily assessed  
as it dispenses with the

with margin alignment

The second method described has the advantage that up to 8 letters per line may be compensated. Insertions for the number of letters which come outside the line, and extensions for the number of letters which fall short of it may thus be anticipated and spread over the whole line.

Insertions are made by writing the word which is to be compressed in the following manner: depress space bar, type the first letter and then release the space bar — depress space bar — type — release space bar etc.

To lengthen lines proceed as follows: after typing the last letter of a word depress space bar, release it and press again, type the first letter of the next word and release the space bar — depress space bar — type a letter etc. After typing the last letter release space bar and tap it two more times. Then continue writing the next word.

---

### CAREFUL MAINTENANCE GUARANTEES DURABILITY

#### *Cleaning*

If the machine is in constant use it should be cleaned every morning. Lift the front cover (19) and dust with a clean brush, cleaning the type with a special wire brush and, if necessary, a little petrol. A sheet of paper should be placed under the type levers while cleaning. The platen may be cleaned with methylated spirit but never with petrol.

#### *Oiling*

Moving parts, and those subject to friction require oiling occasionally. A thin acid-free office machine oil should be used taking care to remove all old oil before applying new. Never oil the segment, the line space wheel or the type guide.

#### *Repairs*

Damaged machines should be immediately handed over to an expert typewriter mechanic. Repairs and adjustment call for the specialised attention which he alone can give.

OLYMPIA WERKE AG · WILHELMSHAVEN

ORDER PREMIUM HIGH-RESOLUTION COLOR OPERATING INSTRUCTIONS:

[CLASSICVINTAGETYPEWRITERS.COM](http://CLASSICVINTAGETYPEWRITERS.COM)